

# Son of Hyde

Version 05/2010

One of the great things about the new V2 Series of pedals is that you can now get your favorite Visual Sound effects in single effect pedals... something that has long been requested by musicians. Son of Hyde, as you may have guessed, is the distortion channel of Jekyll & Hyde. It has a wide range of sounds that can be discovered by using the Mid knob to adjust the midrange, a Bright switch to go from a more compressed distortion to very bright, along with Drive, Treble, and Volume knobs to set the overall style of sound. With the user-friendly controls, the sonic possibilities are endless.

The Son of Hyde also has a very effective yet subtle noise gate, set to "On" at the factory. You'll probably want to leave it on, but if you really don't want it, you can turn it off with the mini switch located inside the bottom of the pedal. Also inside the pedal is a Bass control that you can set according to your playing style and amp.

Following are some settings to get you started:



## Internal Controls:

Noise Gate Level (early versions)  
- later versions have wire here  
since the Level pot was always  
used at the minimum setting.

Noise Gate On/Off

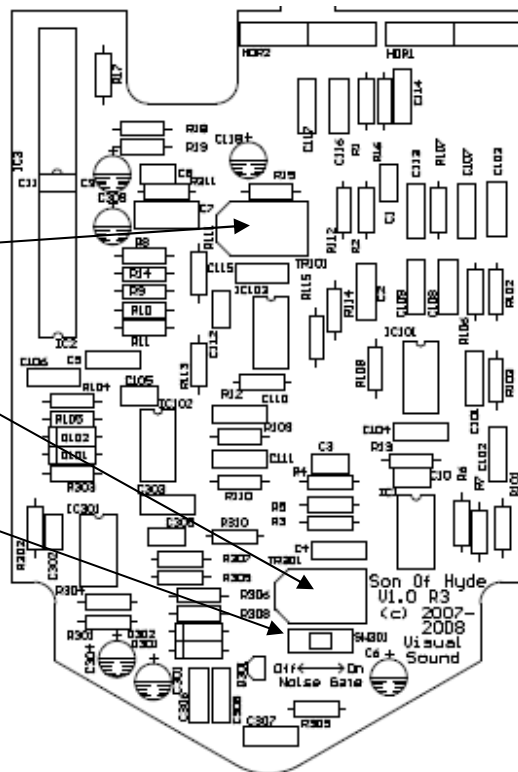

Power with either a 9V alkaline battery or 9VDC regulated power supply like the 1 SPOT.